



# BEAVER LAKE FIRE DEPARTMENT

## BOARD OF DIRECTORS MINUTES



Date: **Tuesday, April 8, 2025**

Time: **6:00 p.m.**

Place: **Beaver Lake Fire Department, Station 1**

Location: **16035 Cypress LN, Rogers AR 72756**

Zoom Link: [Watch the meeting Zoom ID 895 9812 4894](#)

### 1. CALL TO ORDER

- 1.1. Directors attending in person: Jeff Easley, Monte Gagliardi, Curtis Hathcock, Jerry Hudlow, Steve Long, Laura Tucker (6 of 10)
- 1.2. Special Board Members attending in person: Chief Qualls
- 1.3. Attending via Video: Todd Weber, Justin Stanbery
- 1.4. Absent: Gisela Mejia, Larry Smith
- 1.5. Quorum Status. Quorum is requirements met. Six (6) Directors present in person and one (1) present via Zoom.

### 2. Chairman Comments.

### 3. Disposition of Previous Meeting Minutes.

- 3.1. Review Board of Directors Meeting Minutes for March 11, 2025.
- 3.2. **Motion made by Steve Long to approve BOD March Meeting minutes. Motion seconded by Monte Gagliardi. Motion approved by unanimous voice vote.**

4. **Open to Public Comments.** No comments presented by members present. One quest recognized, Jennifer Qualls, spouse of Chief Qualls.

### 5. Reports of Officers

- 5.1. Fire Chief Operations Report.

- 5.1.1. Reviewed monthly response numbers. (charts will be updated be fore the meeting, when available)

- 5.1.1.1. Monthly totals distributions was reversed from the norm. Fire incidents were higher than EMS calls. Mostly due to the unusually windy condition combined with dry weather. BLFD assisted on a wildland fire in the railroad cut area of Piney Point's GSA. Chief Qualls asked board members and guest present to reiterate that anyone desiring to an open burn needs to check with their local fire representative or better yet check with the county to determine if an open burn ban is in effect.

# BEAVER LAKE FIRE DEPARTMENT

## BOARD OF DIRECTORS MINUTES

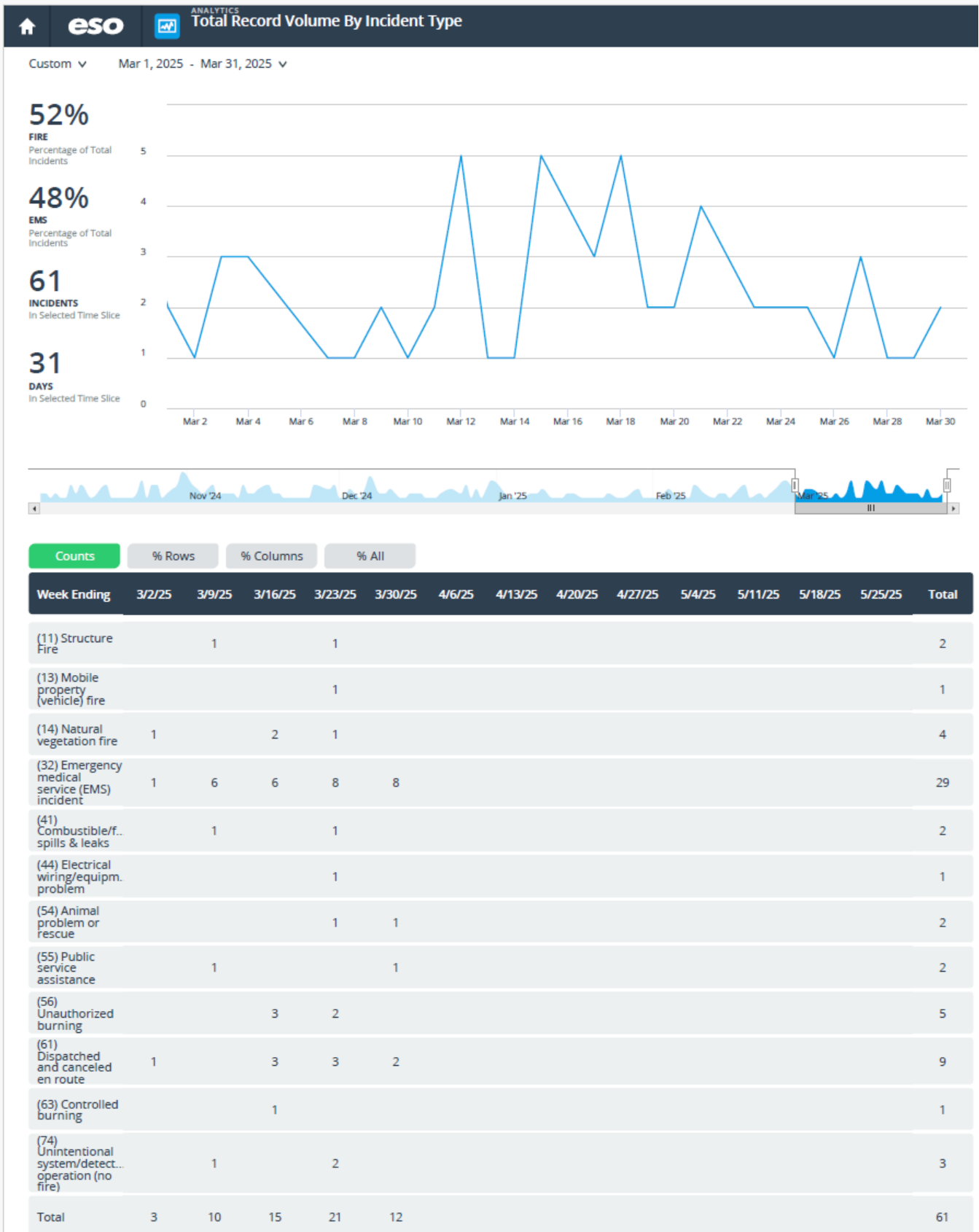

# BEAVER LAKE FIRE DEPARTMENT

## BOARD OF DIRECTORS MINUTES

5.1.1.2. Chairperson communicated a story he had recently been told about where a member of another Volunteer Fire Department was the first to arrive at a scene where the situation might be somewhat hazardous due to possible criminal activity at the scene. Chief Qualls answered that security of any fire is paramount. Responders are trained to keep themselves safe and wait for law enforcement response when needed.

5.1.2. Acquisition of new Firefighting/Rescue Apparatus. Chief Qualls reviewed some diagrams depicting the basic design of the vehicle. Things are moving along. Current projects indicate the apparatus could be ready during the last quarter of this calendar year. Pictures are included at the end of this document.

5.1.3. Firefighter Elijah Ballou is at Fire Academy in Camden. He is doing well and is due to graduate April 25.

5.1.4. Live-in firefighter coordinated some donated labor and materials to redo flooring in the station.

5.1.5. Station One had the HVAC cooling system fail. Replacement has been completed to put it back in operation. Chief Qualls noted that the cost will show in the next month financial documents but emphasized that the amount was covered under planned provisions budgeted for this year.

5.1.6. Backup Generator Project. No update.

5.2. President's Report. No Updates.

5.3. Treasurer's Report.

5.3.1. Review Monthly Financial Documents. Laura Tucker presented the monthly financial documents. The only thing of note was that the Firewise funds for this year came in at \$1000. This was expected; however, the board had estimated the amount to be at \$2500 for budget purposes. This is not a significant impact to the budget and the board will adjust the amount accordingly for next year's budget.

**5.3.2. Motion made by Curtis Hathcock to approve monthly Balance sheets, P &L, and Budget review documents for March. Motion seconded by Jerry Hudlow. Motion approved by unanimous voice vote.**

5.4. Secretary's Report. No Update.

6. **Reports of Committees** – Chairperson Easley provided general information of task to evaluate the needs for a new building to house equipment at fire station 1. The committee has started developing the plan but no major progress worth reporting.

7. **New Business.** Chief Qualls pitched the idea of developing an employee recognition program to highlight significant achievements or events. The Chief was given authority begin developing what such a program would potentially look like. Directors fully supported the idea and looked forward to updates on development of the program.

# BEAVER LAKE FIRE DEPARTMENT

## BOARD OF DIRECTORS MINUTES

### 8. Old Business

8.1. Acquisition of new Firefighting/Recue Apparatus.

8.2. Backup Generator Project.

8.3. New Building for equipment Storage.

8.4. BLFD Bylaws Review/Update/Amendment.

8.4.1. Chairman Comments.

8.4.2. Minor re-write of paragraph 3.5.1.5.5, to specify the number of director positions up for election during even and odd years. Brief discussion explaining how a specific number of director positions are to be filled during even year elections and the remaining are filled during odd year elections. Given directors serve a 2-year term, this means approximately half of the board positions are filled each year.

8.4.3. Adding paragraph to integrate provisions of current Bylaws amendment 2.

8.4.3.1. Adding a paragraph 3.5.3.1 specifies the minimum number of officers of the Board of Directors.

8.4.3.2. Removed paragraph referencing Vice President since it is not a required officer based upon the amendment we passed. Director Jerry Hudlow suggested that we keep the Vice President position in the bylaws due to the language in A.C.A. § 4-28-213. Unanimous concurrence of board members present was reached.

8.4.3.3. Adding a paragraph 2.5.3.10 Assistant Treasurer. Provides the description and broad responsibilities of the position. In the spirit of the previous paragraph, concurrence was reached by the board members to remove this position.

Note: No real progress was made on the rest of the subparagraphs listed in the agenda. The Chairperson reviewed his interpretation of who has the authority to vote for issues related to the determination of dues assessed for services provided by BLFD. Discussion repeatedly centered on voting being conducted by the Benton County Election Commission or the corporation's members. Further clarification of what the "Special Election" referenced in A.C.A. § 14-20-108 Dues for volunteer fire departments determines. After some lengthy discussion, no agreed upon understanding was reached. Therefore, these items will continue to be discussed during future meetings.

8.4.4. Review of Paragraph 2.2.2. Collection of Dues. Rewrite proposed. Word smithing to clarify that a member who is delinquent on payment of annual dues will not be able to avoid invoicing of services provided under the law. Left open for further discussion.

8.4.5. Review of Paragraph 2.3. Determination and Collection of Response Charges. Rewrite proposed. Word smithing to clarify that a member who is delinquent on payment of annual dues will not be able to avoid invoicing of services provided under the law. Left open for further discussion.

# BEAVER LAKE FIRE DEPARTMENT

## BOARD OF DIRECTORS MINUTES

8.4.6. Review of Paragraph 2.2 Determination of Dues. Left open for further discussion.

8.4.7. Review of Paragraph 3.1 Voting Rights of Members. Left open for further discussion.

8.4.7.1. Re-open discussion on Paragraph 2.1.1 Members. Left open for further discussion.

8.4.7.2. Review of paragraph 3.1 is directly related to paragraph 2.1.1. Left open for further discussion.

### 9. Other Business.

9.1. FY 2025 Annual Membership Meeting. Need to finalize a date for meeting. Proposed dates are September 13 or 20. Tentatively, September 20 was determined to be the best date. A vote to make an official determination will be done next month.

9.2. Next Board Meeting scheduled for May 13, 2025, at BLFD Fire Station 1, 16035 Cypress LN, Rogers AR 72756.

### 10. Adjournment.

A handwritten signature in blue ink, appearing to read "Curtis Hathcock", with a long horizontal flourish extending to the right.

SUBMITTED BY: Curtis Hathcock, Board Secretary

# BEAVER LAKE FIRE DEPARTMENT

## BOARD OF DIRECTORS MINUTES

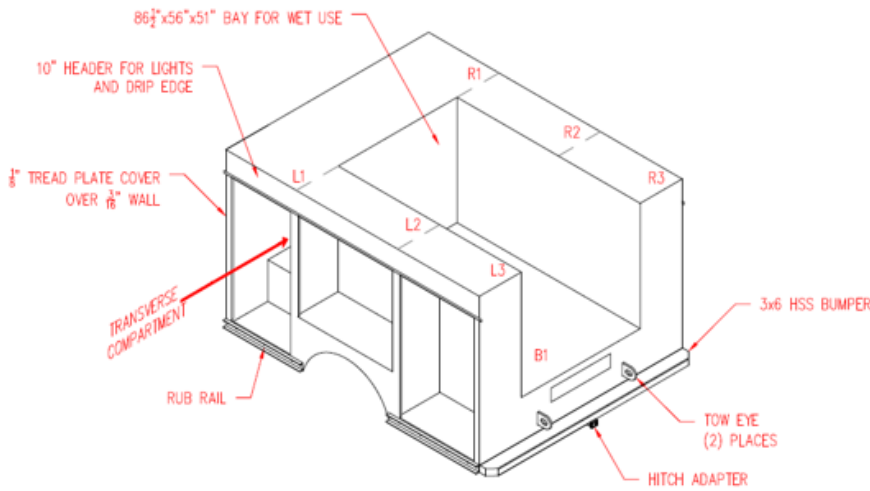

ROLL UP DOORS NOT SHOWN FOR CLARITY

	<b>BANNER</b> FIRE EQUIPMENT, INC.						
	Oklahoma City, OK. 405-224-2596						
PROPRIETARY AND CONFIDENTIAL INFORMATION CONTAINED IN THIS DRAWING IS THE SOLE PROPERTY OF BANNER FIRE EQUIPMENT. ANY REPRODUCTION WITHOUT THE WRITTEN PERMISSION OF BANNER FIRE EQUIPMENT IS PROHIBITED.	Client		Beaver Lake FD				
	Job Name		F550 Wet Rescue Body				
	Description		Apparatus Layout				
	Job Number		Approval				
	Drawn	Date	App'd	Scale	Drawing No.	Sheet #	Rev.
ged	3/25/25		NTS	1	E1	0	

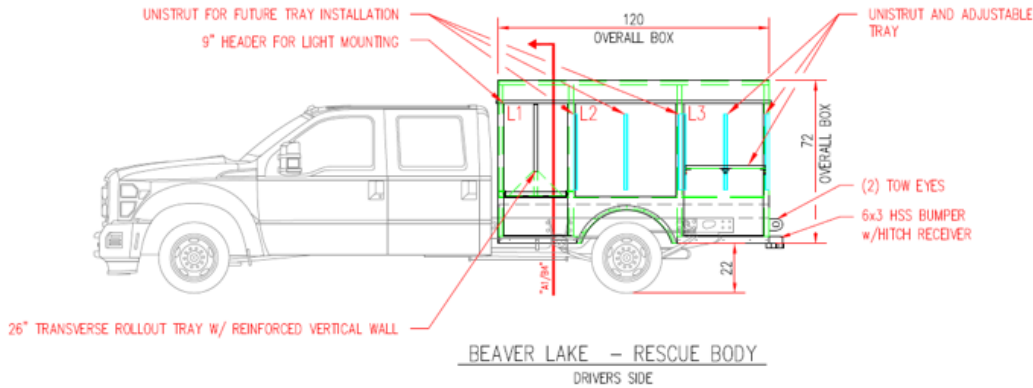

BEAVER LAKE - RESCUE BODY  
DRIVERS SIDE

ROLL UP DOORS NOT SHOWN FOR CLARITY

**NOTES:**

- L1- UPPER - 33"x49" TRANSVERSE FRONT COMPARTMENT  
w/ 28 3/8"x58 1/2" OPENING  
26" ROLL OUT TRAY WITH 40" REINFORCED VERTICAL WALL  
LOWER - 33"x17"x18 1/2"
- L2- 48"x49"x18 1/2" OVER WHEEL COMPARTMENT  
w/ 44 1/2"x41 1/2" OPENING  
UNISTRUT FOR FUTURE TRAY INSTALLATION
- L3- 38 3/4"x68"x18 1/2" REAR COMPARTMENT  
w/ 35 3/8"x58 1/2" OPENING  
ADJUSTABLE SHELF

	<b>BANNER</b> FIRE EQUIPMENT, INC.						
	Oklahoma City, OK. 405-224-2596						
PROPRIETARY AND CONFIDENTIAL INFORMATION CONTAINED IN THIS DRAWING IS THE SOLE PROPERTY OF BANNER FIRE EQUIPMENT. ANY REPRODUCTION WITHOUT THE WRITTEN PERMISSION OF BANNER FIRE EQUIPMENT IS PROHIBITED.	Client		Beaver Lake FD				
	Job Name		F550 Wet Rescue Body				
	Description		Driver Side Layout				
	Job Number		Approval				
	Drawn	Date	App'd	Scale	Drawing No.	Sheet #	Rev.
ged	3/25/25		NTS	1	E2	0	

# BEAVER LAKE FIRE DEPARTMENT

## BOARD OF DIRECTORS MINUTES

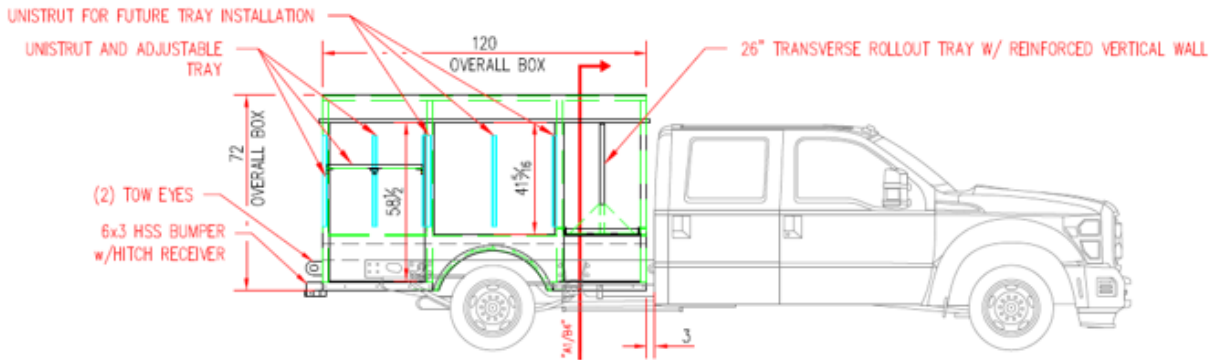

BEAVER LAKE – RESCUE BODY  
PASSENGER SIDE

**NOTES:**

- R1- UPPER – 33"x49" TRANSVERSE FRONT COMPARTMENT  
w/ 28 $\frac{1}{2}$ "x58 $\frac{1}{2}$ " OPENING  
26" ROLL OUT TRAY WITH 40" REINFORCED VERTICAL WALL  
LOWER – 33"x17"x18 $\frac{1}{2}$ "
- R2- 48"x49x18 $\frac{1}{2}$ " OVER WHEEL COMPARTMENT  
w/ 44 $\frac{1}{2}$ "x41 $\frac{1}{8}$ " OPENING  
UNISTRUT FOR FUTURE TRAY INSTALLATION
- R3- 38 $\frac{1}{2}$ "x68"x18 $\frac{1}{2}$ " REAR COMPARTMENT  
w/ 35 $\frac{1}{2}$ "x58 $\frac{1}{2}$ " OPENING  
ADJUSTABLE SHELF

ROLL UP DOORS NOT SHOWN FOR CLARITY

 <b>BANNER</b> FIRE EQUIPMENT, INC.  PROPRIETARY AND CONFIDENTIAL INFORMATION CONTAINED IN THIS DRAWING IS THE SOLE PROPERTY OF BANNER FIRE EQUIPMENT. ANY REPRODUCTION WITHOUT THE WRITTEN PERMISSION OF BANNER FIRE EQUIPMENT IS PROHIBITED.	<b>BANNER</b> FIRE EQUIPMENT, INC.					
	Oklahoma City, OK. 405-224-2596					
	Client		Beaver Lake FD			
	Job Name		F550 Wet Rescue Body			
Description		Passenger Side Layout				
Job Number		Approval				
Drawn	Date	App'd	Scale	Drawing No.	Sheet #	Rev.
ged	3/25/25		NTS	1	E3	0

**NOTES:**

- B1- 58"x41"x84" OPEN REAR COMPARTMENT  
REMOVABLE SHELF FOR BOOSTER REEL
- B2- 28 $\frac{1}{2}$ "x52"x72"~96" "MARSUPIAL" COMPARTMENT  
SEE COMPARTMENT LAYOUT DETAIL FOR DIMENSIONS.  
THUMB LATCH DOOR.

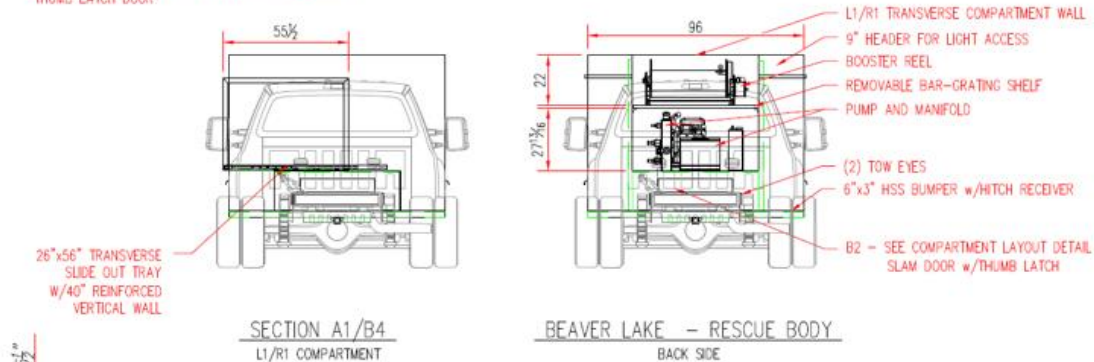

BEAVER LAKE – RESCUE BODY  
BACK SIDE

ROLL UP DOORS NOT SHOWN FOR CLARITY



BEAVER LAKE RESCUE  
"B2 COMPARTMENT"  
LAYOUT DETAIL

 <b>BANNER</b> FIRE EQUIPMENT, INC.  PROPRIETARY AND CONFIDENTIAL INFORMATION CONTAINED IN THIS DRAWING IS THE SOLE PROPERTY OF BANNER FIRE EQUIPMENT. ANY REPRODUCTION WITHOUT THE WRITTEN PERMISSION OF BANNER FIRE EQUIPMENT IS PROHIBITED.	<b>BANNER</b> FIRE EQUIPMENT, INC.					
	Oklahoma City, OK. 405-224-2596					
	Client		Beaver Lake FD			
	Job Name		F550 Wet Rescue Body			
Description		Rear / Slide Out Layout				
Job Number		Approval				
Drawn	Date	App'd	Scale	Drawing No.	Sheet #	Rev.
ged	3/25/25		NTS	1	E4	0

# BEAVER LAKE FIRE DEPARTMENT

## BOARD OF DIRECTORS MINUTES

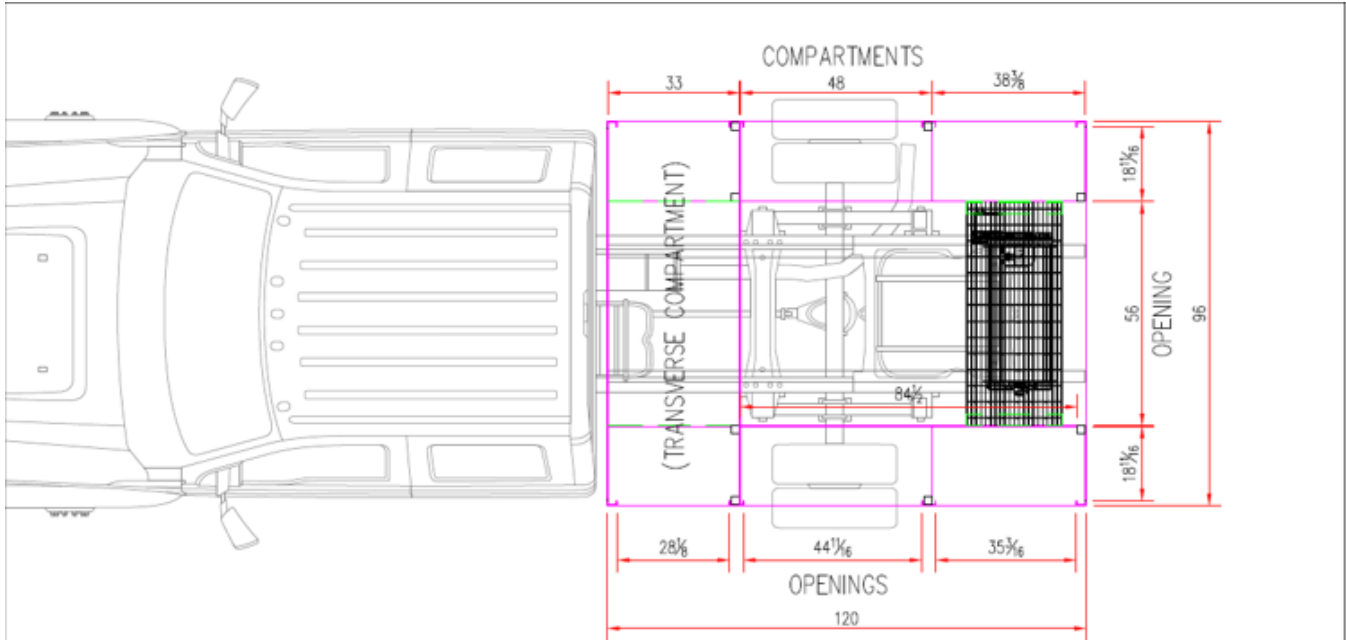

**BEAVER LAKE – RESCUE BODY**  
COMPARTMENT LAYOUTS

 <small>PROPRIETARY AND CONFIDENTIAL INFORMATION CONTAINED IN THIS DRAWING IS THE SOLE PROPERTY OF BANNER FIRE EQUIPMENT. ANY REPRODUCTION WITHOUT THE WRITTEN PERMISSION OF BANNER FIRE EQUIPMENT IS PROHIBITED</small>	<b>BANNER</b> <small>FIRE EQUIPMENT, INC.</small>						
	<small>Oklahoma City, OK. 405-224-2596</small>						
	<b>Client</b>		Beaver Lake FD				
	<b>Job Name</b>		F550 Wet Rescue Body				
	<b>Description</b>		Compartment Layouts				
	<b>Job Number</b>		<b>Approval</b>				
<b>Drawn</b>	<b>Date</b>	<b>App'd</b>	<b>Scale</b>	<b>Drawing No.</b>	<b>Sheet #</b>	<b>Rev.</b>	
ged	3/25/25		NTS	1	E5	0	